

9RLS2 Submittal

AOU9RLS2, ASU9RLS2 Inverter Driven Heat Pump



Job Name: _____
 Location: _____
 Engineer: _____
 Submitted to: _____
 Submitted by: _____
 Reference: _____

Approval: _____
 Date: _____
 Construction: _____
 Unit #: _____
 Drawing #: _____

Outdoor Unit Power 208-230/VAC-1Ph-60Hz
 Available Voltage Range 187-253VAC
 Fuse Size, Max. 20A
 MCA 10.5A

Compressor Inverter Driven Variable Speed DC Rotary
 No. used 1
 Output 850W
 Lubrican Oil POE (RB68)

Fan type Propeller
 Motor Output 115W
 Airflow Rate Cooling/Heating (High) 1082 / 1840CFM

Refrigerant 410A
 Outdoor Unit 2lbs 10oz
 Contrlol Electronic Expansion Valve
 O.D. Discharge (in) 1/4"(Flare)
 O.D Suction (in) 3/8"(Flare)

Dimensions H x W x D
 Uncrated (in) 24-1/2 x 31-3/32 x 11-11/32
 (mm) (620 x 790 x 290)
 Crated (in) 28-1/16 x 37-7/32 x 15-9/16
 (mm) (713 x 945 x 395)

Weight Outdoor
 Net 84lbs (38kg)
 Gross Shipping 93lbs (42kg)

Cooling
 Rated Capacity 9,000BTU/h
 Min-Max Capacity 3,100~12,000BTU/h
 Rated Power Input 2.64kw
 Max. Power Input 3.60kw
 SEER 27.2
 Outdoor Sound Rating 48dB

Heating
 Rated Capacity 12,000BTU/h
 Min-Max Capacity 3,100~22,000BTU/h
 Rated Power Input 3.52kw
 Max. Power Input 6.45kw
 HSPF 12.5
 Outdoor Sound Rating 49dB

Piping Lengths
 Max. Piping Length (Total) 66ft
 Max. Pipe Height Difference 49ft
 Connection method (Flared)

Operating Range
 Cooling 14°F~115°F DB
 Heating -5°F~75°F DB

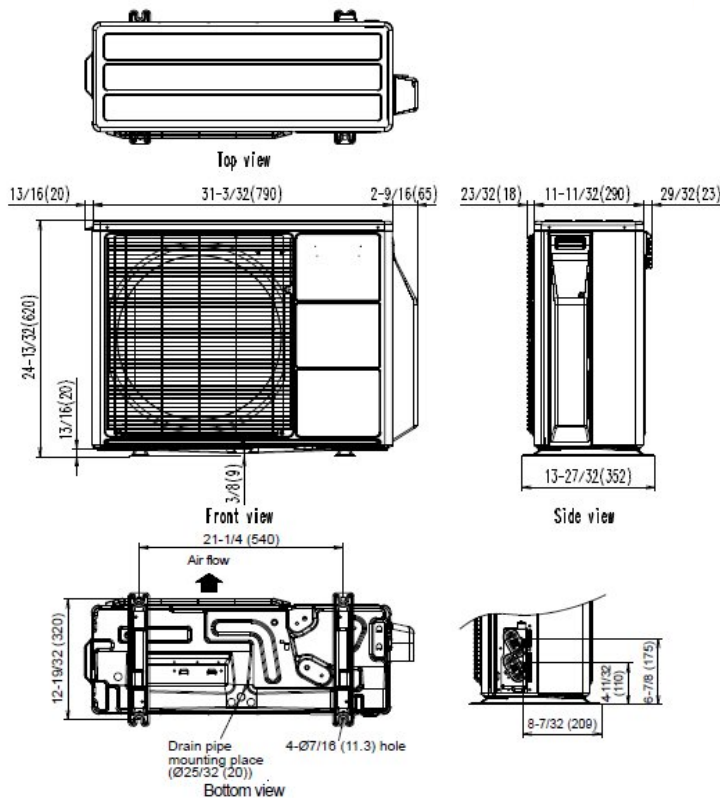

Fujitsu General America, Inc.
 Fairfield, NJ 07004
 Toll Free: 1-888-888-3424
 Fax: (973) 836-0447
 www.fujitsugeneral.com

Fujitsu products are subject to continuous improvements. Fujitsu reserves the right to modify product design, specifications and information in this data sheet without notice and without incurring any obligations.

Note: Specifications are based on the following conditions.

Power source of specifications : 230V

Cooling: Indoor temperature of 80°F(26.67°C)DB / 67°F(19.44°C)WB, and outdoor temperature of 95°F(35°C)DB/75°F(23.89°C)WB.

Heating: Indoor temperature of 70°F(21.11°C)DB / 60°F(15.56°C)WB, and outdoor temperature of 47°F(8.33°C)DB/43°F(6.11°C)WB.

Pipe length : 24ft. 7in.(7.5m), Height difference : 0 ft.(0m) [Outdoor unit - Indoor unit]



