

# AIR CONDITIONER INDOOR UNIT Wall Mounted Type

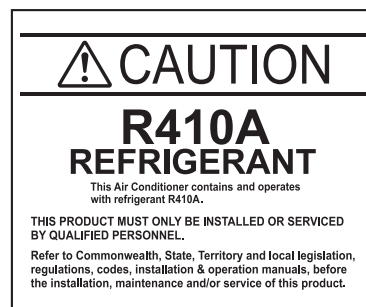

English

Français

Español

# INSTALLATION MANUAL

For authorized service personnel only.

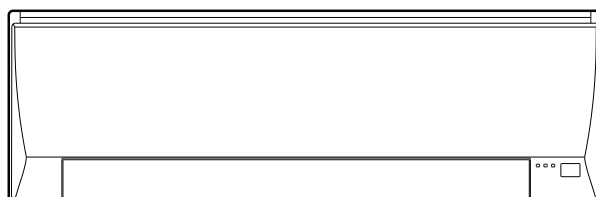

## Contents

<b>1. SAFETY PRECAUTIONS</b> .....	<b>2</b>	<b>7. ELECTRICAL WIRING</b> .....	<b>9</b>
1.1. IMPORTANT! Please read before starting .....	2	7.1. Wiring system diagram.....	9
1.2. SPECIAL PRECAUTIONS .....	2	7.2. How to the install the indoor unit wire harness .....	9
<b>2. ABOUT THE UNIT</b> .....	<b>3</b>	7.3. How to connect wiring to the terminals .....	10
2.1. Precautions for using R410A refrigerant .....	3	<b>8. FINISHING</b> .....	<b>11</b>
2.2. Special tools for R410A.....	3	<b>9. FRONT PANEL REMOVAL AND INSTALLATION</b> .....	<b>11</b>
2.3. For authorized service personnel only. ....	3	<b>10. TEST RUN</b> .....	<b>12</b>
2.4. Accessories .....	4	<b>11. REMOTE CONTROLLER INSTALLATION</b> .....	<b>12</b>
<b>3. GENERAL</b> .....	<b>4</b>	11.1. Remote controller holder installation .....	12
3.1. Type of copper pipe and insulation material .....	4	<b>12. FUNCTION SETTING</b> .....	<b>13</b>
3.2. Additional materials required for installation.....	4	12.1. INDOOR UNIT (Setting by remote controller) ....	13
3.3. Operating range .....	5	<b>13. ERROR CODES</b> .....	<b>15</b>
<b>4. ELECTRICAL REQUIREMENT</b> .....	<b>5</b>	<b>14. CUSTOMER GUIDANCE</b> .....	<b>16</b>
<b>5. SELECTING THE MOUNTING POSITION</b> .....	<b>5</b>		
5.1. Indoor unit .....	5		
<b>6. INSTALLATION WORK</b> .....	<b>5</b>		
6.1. Installation dimensions.....	5		
6.2. Indoor unit piping direction .....	5		
6.3. Cutting the hole in the wall for the connecting piping ...	6		
6.4. Installing the wall hook bracket .....	6		
6.5. Forming the drain hose and pipe .....	6		
6.6. Flare connection (Pipe connection).....	7		

# 1. SAFETY PRECAUTIONS

## 1.1. IMPORTANT! Please read before starting

This air conditioning system meets strict safety and operating standards.

As the installer or service person, it is an important part of your job to install or service the system so it operates safely and efficiently.

**For safe installation and trouble-free operation, you must:**

- Carefully read this instruction booklet before beginning.
- Follow each installation or repair step exactly as shown.
- Observe all local, state, and national electrical codes.
- Pay close attention to all danger, warning, and caution notices given in this manual.

**WARNING:** This symbol refers to a hazard or unsafe practice which can result in severe personal injury or death.

**CAUTION:** This symbol refers to a hazard or unsafe practice which can result in personal injury and the potential for product or property damage.

- Hazard alerting symbols



Electrical



Safety/alert

### If Necessary, Get Help

These instructions are all you need for most installation sites and maintenance conditions. If you require help for a special problem, contact our sales/service outlet or your certified dealer for additional instructions.

### In Case of Improper Installation

The manufacturer shall in no way be responsible for improper installation or maintenance service, including failure to follow the instructions in this document.

## 1.2. SPECIAL PRECAUTIONS

### When Wiring

**ELECTRICAL SHOCK CAN CAUSE SEVERE PERSONAL INJURY OR DEATH. ONLY A QUALIFIED, EXPERIENCED ELECTRICIAN SHOULD ATTEMPT TO WIRE THIS SYSTEM.**

- Do not supply power to the unit until all wiring and tubing are completed or reconnected and checked.
- Highly dangerous electrical voltages are used in this system. Carefully refer to the wiring diagram and these instructions when wiring. Improper connections and inadequate earthing (grounding) can cause accidental injury or death.
- Earth (Ground) the unit following local electrical codes.
- Connect all wiring tightly. Loose wiring may cause overheating at connection points and a possible fire hazard.

### When Transporting

Be careful when picking up and moving the indoor and outdoor units. Get a partner to help, and bend your knees when lifting to reduce strain on your back. Sharp edges or thin aluminum fins on the air conditioner can cut your fingers.

### When Installing...

#### ...In a Ceiling or Wall

Make sure the ceiling/wall is strong enough to hold the unit's weight. It may be necessary to construct a strong wood or metal frame to provide added support.

#### ...In a Room

Properly insulate any tubing run inside a room to prevent "sweating" that can cause dripping and water damage to walls and floors.

#### ...In Moist or Uneven Locations

Use a raised concrete pad or concrete blocks to provide a solid, level foundation for the outdoor unit. This prevents water damage and abnormal vibration.

#### ...In an Area with High Winds

Securely anchor the outdoor unit down with bolts and a metal frame.

Provide a suitable air baffle.

#### ...In a Snowy Area (for Heat Pump-type Systems)

Install the outdoor unit on a raised platform that is higher than drifting snow.

### When Connecting Refrigerant Tubing

- Keep all tubing runs as short as possible.
- Use the flare method for connecting tubing.
- Apply refrigerant lubricant to the matching surfaces of the flare and union tubes before connecting them, then tighten the nut with a torque wrench for a leak-free connection.
- Check carefully for leaks before opening the refrigerant valves.

### When Servicing

- Turn the power OFF at the main circuit breaker panel before opening the unit to check or repair electrical parts and wiring.
- Keep your fingers and clothing away from any moving parts.
- Clean up the site after you finish, remembering to check that no metal scraps or bits of wiring have been left inside the unit being serviced.
- After installation, explain correct operation to the customer, using the operating manual.

 **DANGER**

**Never touch electrical components immediately after the power supply has been turned off. Electrical shock may occur. After turning off the power, always wait 5 minutes or more before touching electrical components.**

## 2. ABOUT THE UNIT

### 2.1. Precautions for using R410A refrigerant

The basic installation work procedures are the same as conventional refrigerant (R22) models.

However, pay careful attention to the following points:

- Since the working pressure is 1.6 times higher than that of conventional refrigerant (R22) models, some of the piping and installation and service tools are special. (See the table below.)

Especially, when replacing a conventional refrigerant (R22) model with a new refrigerant R410A model, always replace the conventional piping and flare nuts with the R410A piping and flare nuts.

- Models that use refrigerant R410A have a different charging port thread diameter to prevent erroneous charging with conventional refrigerant (R22) and for safety. Therefore, check beforehand. [The charging port thread diameter for R410A is 1/2 inch.]
- Be more careful that foreign matter (oil, water, etc.) does not enter the piping than with refrigerant (R22) models. Also, when storing the piping, securely seal the opening by pinching, taping, etc.
- When charging the refrigerant, take into account the slight change in the composition of the gas and liquid phases. And always charge from the liquid phase where refrigerant composition is stable.

### 2.2. Special tools for R410A

Tool name	Contents of change
Gauge manifold	Pressure is high and cannot be measured with a conventional (R22) gauge. To prevent erroneous mixing of other refrigerants, the diameter of each port has been changed. It is recommended the gauge with seals -0.1 to 5.3 MPa (30 in.Hg to 768 psi) for high pressure. -0.1 to 3.8 MPa (30 in.Hg to 551 psi) for low pressure.
Charge hose	To increase pressure resistance, the hose material and base size were changed.
Vacuum pump	A conventional vacuum pump can be used by installing a vacuum pump adapter.
Gas leakage detector	Special gas leakage detector for HFC refrigerant R410A.

#### Copper pipes

It is necessary to use seamless copper pipes and it is desirable that the amount of residual oil is less than 0.004 oz/100ft. Do not use copper pipes having a collapsed, deformed or discolored portion (especially on the interior surface). Otherwise, the expansion valve or capillary tube may become blocked with contaminants.

As an air conditioner using R410A incurs pressure higher than when using R22, it is necessary to choose adequate materials.

#### WARNING

- Do not use the existing (for R22) piping and flare nuts.  
If the existing materials are used, the pressure inside the refrigerant cycle will rise and cause failure, injury, etc. (Use the special R410A materials.)
- When installing and relocating the air conditioner, do not mix gases other than the specified refrigerant (R410A) to enter the refrigerant cycle.  
If air or other gas enters the refrigerant cycle, the pressure inside the cycle will rise to an abnormally high value and cause failure, injury, etc.

### 2.3. For authorized service personnel only.

#### WARNING

- For the air conditioner to operate satisfactorily, install it as outlined in this installation manual.
- Connect the indoor unit and outdoor unit or branch box with the air conditioner piping and cables available from your local distributor. This installation manual describes the correct connections using the installation set available from your local distributor.
- Installation work must be performed in accordance with national wiring standards by authorized personnel only.
- Do not turn on the power until all installation work is complete.









#### CAUTION

This installation manual describes how to install the indoor unit only.  
To install the outdoor unit or branch box, refer to the installation manual included with the outdoor unit or branch box.

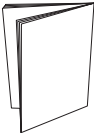
- Be careful not to scratch the air conditioner when handling it.
- After installation, explain correct operation to the customer, using the operating manual.

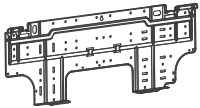
## 2.4. Accessories

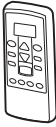
The following installation accessories are supplied. Use them as required.

Name and Shape	Q'ty	Name and Shape	Q'ty
Operating manual 	1	Remote controller holder 	1
Installation Manual (This manual) 	1	Cloth tape 	1
Wall hook bracket 	1	Tapping screw (large) 	5
Remote controller 	1	Tapping screw (small) 	2
Battery 	2		

The following items are necessary to install this air conditioner. (The items are not included with the air conditioner and must be purchased separately.)

Name	Q'ty
Connection pipe assembly	1
Connection cable	1
Wall pipe	1
Decorative tape	1
Vinyl tape	1
Wall cap	1
Saddle	1 set
Drain hose	1
Tapping screws	1 set
Sealant	1

## 3. GENERAL

This INSTALLATION MANUAL briefly outlines where and how to install the air conditioning system. Please read over the entire set of instructions for the indoor and outdoor units and make sure all accessory parts listed are with the system before beginning.

### 3.1. Type of copper pipe and insulation material

#### CAUTION

Refer to the installation manual for the outdoor unit for description of allowable pipe length and height difference.

Diameter	
Liquid pipe	Gas pipe
6.35 mm (1/4 in.)	9.52 mm (3/8 in.)

#### CAUTION

Install heat insulation around both the gas and liquid pipes. Failure to do so may cause water leaks. Use heat insulation with heat resistance above 248°F (120°C) Reverse cycle model only. In addition, if the humidity level at the installation location of the refrigerant piping is expected to exceed 70%, install heat insulation around the refrigerant piping. If the expected humidity level is 70-80%, use heat insulation that is 15 mm (19/32 in.) or thicker and if the expected humidity exceeds 80%, use heat insulation that is 20 mm (25/32 in.) or thicker. If heat insulation is used that is not as thick as specified, condensation may form on the surface of the insulation. In addition, use heat insulation with heat conductivity of 0.045 W/(m•K) or less at 68°F (20°C).

### 3.2. Additional materials required for installation

- A. Refrigeration (armored) tape
- B. Insulated staples or clamps for connecting wire (See your local electrical codes.)
- C. Putty
- D. Refrigeration lubricant
- E. Clamps or saddles to secure refrigerant piping

### 3.3. Operating range

	COOL/DRY mode	HEAT mode
Indoor temperature	64 to 90°F (18 to 32°C)	60 to 88°F (16 to 30°C)
Indoor humidity	80% or less	—

## 4. ELECTRICAL REQUIREMENT

The indoor unit is powered from the outdoor unit or branch box. Do not power indoor unit from separate power source.

### ⚠ WARNING

- Refer to local codes for acceptable cable type.

Cable	Cable size	Remarks
Connection cable	14AWG	3 cable + Earth (Ground), 1 Ø 115V

Max. Cable Length: Limit voltage drop to less than 2%. Increase cable gauge if voltage drop is 2% or more.

## 5. SELECTING THE MOUNTING POSITION

Decide the mounting position with the customer as follows:

### 5.1. Indoor unit

- (1) Install the indoor unit level on a strong wall which is not subject to vibration.
- (2) The inlet and outlet ports should not be obstructed : the air should be able to blow all over the room.
- (3) Install the unit a dedicated electrical branch circuit.
- (4) Do not install the unit where it will be exposed to direct sunlight.
- (5) Install the unit where connection to the outdoor unit or branch box is easy.
- (6) Install the unit where the drain pipe can be easily installed.
- (7) Take servicing, etc. into consideration and leave the spaces shown in [6.1. Installation dimensions]. Also install the unit where the filter can be removed.

Correct initial installation location is important because it is difficult to move unit after it is installed.

### ⚠ WARNING

- Select installation locations that can properly support the weight of the indoor. Install the units securely so that they do not topple or fall.

### ⚠ CAUTION

- Do not install the unit in the following areas:
  - Area with high salt content, such as at the seaside. It will deteriorate metal parts, causing the parts to fail or the unit to leak water.
  - Area filled with mineral oil or containing a large amount of splashed oil or steam, such as a kitchen. It will deteriorate plastic parts, causing the parts to fail or the unit to leak water.
  - Area that generates substances that adversely affect the equipment, such as sulfuric gas, chlorine gas, acid, or alkali. It will cause the copper pipes and brazed joints to corrode, which can cause refrigerant leakage.
  - Area that can cause combustible gas to leak, contains suspended carbon fibers or flammable dust, or volatile inflammables such as paint thinner or gasoline. If gas leaks and settles around the unit, it can cause a fire.
  - Area where animals may urinate on the unit or ammonia may be generated.

- Do not use the unit for special purposes, such as storing food, raising animals, growing plants, or preserving precision devices or art objects. It can degrade the quality of the preserved or stored objects.

- Do not install where there is the danger of combustible gas leakage.

- Do not install the unit near a source of heat, steam, or flammable gas.

- Install the unit where drainage does not cause any trouble.

- Install the indoor unit, outdoor unit, branch box, power supply cable, transmission cable, and remote control cable at least 40 in. (1 m) away from a television or radio receivers. The purpose of this is to prevent TV reception interference or radio noise.

(Even if they are installed more than 40 in. (1 m) apart, you could still receive noise under some signal conditions.)

- If children under 10 years old may approach the unit, take preventive measures so that they cannot reach the unit.

- Install the indoor unit on the wall where the height from the floors more than 1800 mm (70 in.).

## 6. INSTALLATION WORK

### 6.1. Installation dimensions

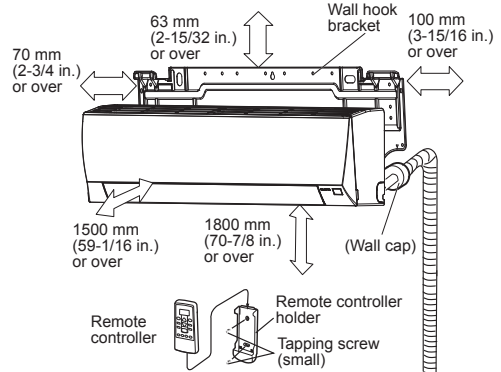

### 6.2. Indoor unit piping direction

The piping can be connected in the 6 directions indicated in the following.

When the piping is connected in direction ②, ③, ④ or ⑤, cut along the piping groove in the side of the front cover with a hacksaw.

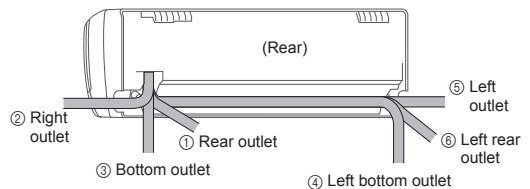

### 6.3. Cutting the hole in the wall for the connecting piping

- (1) Cut a 65 mm (2-9/16 in.) diameter hole in the wall at the position shown in the following.
- (2) Cut the hole so that the outside end is lower (5 to 10 mm (3/16 to 13/32 in.)) than the inside end.
- (3) Always align the center of the wall hole. If misaligned, water leakage will occur.
- (4) Cut the wall pipe to match the wall thickness, stick it into the wall cap, fasten the cap with vinyl tape, and stick the pipe through the hole.
- (5) For left piping and right piping, cut the hole a little lower so that drain water will flow freely.

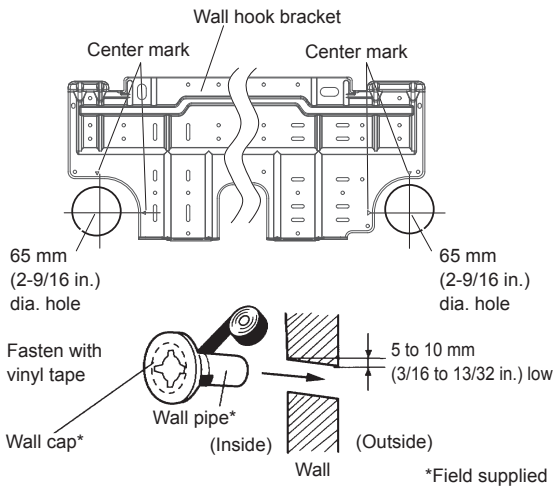

#### **WARNING**

If the wall pipe is not used, the cable interconnecting the indoor unit(s) and outdoor unit or branch box may touch metal and cause electric discharge.

### 6.4. Installing the wall hook bracket

- (1) Install the wall hook bracket so that it is correctly positioned horizontally and vertically. If the wall hook bracket is tilted, water will drip to the floor.
- (2) Install the wall hook bracket so that it is strong enough to support the weight of the unit.
  - Fasten the wall hook bracket to the wall with 5 or more screws through the holes near the outer edge of the bracket.
  - Check that there is no rattle at the wall hook bracket.

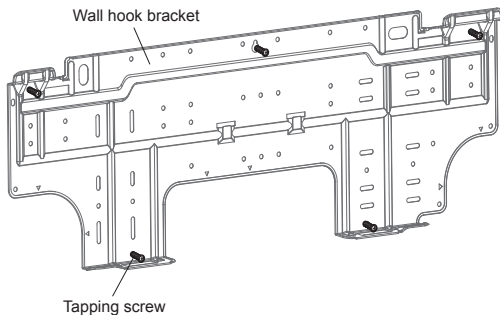

#### **CAUTION**

- Install the wall hook bracket level, both horizontally and vertically.

### 6.5. Forming the drain hose and pipe

#### [Rear piping, Right piping, Bottom piping]

- Install the indoor unit piping in the direction of the wall hole and bind the drain hose and pipe together with vinyl tape.
- Install the piping so that the drain hose is at the bottom.
- Wrap the pipes of the indoor unit that are visible from the outside with decorative tape.

#### [For Left rear piping, Left piping]

Interchange the drain cap and the drain hose.

#### **CAUTION**

- Insert drain hose and drain cap securely. Drain should slope down to avoid water leakage.
- When inserting, be sure not to attach any material besides water. If any other material is attached, it will cause deterioration and water leakage.
- After removing drain hose, be sure not to forget mounting drain cap.
- Be sure to fix the drain hose with tape to the bottom of piping.
- Prevent drain water freezing under low temperature environment.  
When installing indoor unit's drain hose outdoors, necessary measure for frost protection should be taken to prevent drain water freezing.  
Under low temperature environment (when outdoor temperature under 32°F (0°C), after cooling operation is executed, water in the drain hose could be frozen. Once drain water is frozen, the drain hose will be blocked and water leakage may result at the indoor unit.

## Installation method of Drain cap

- Use a hexagonal wrench 4 mm (5/32 in.) at opposite side to insert the drain cap, till the drain cap contacts the tip of drain cock.

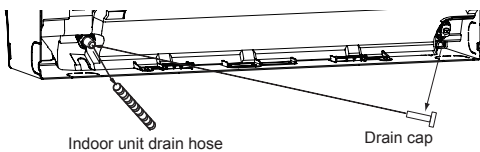
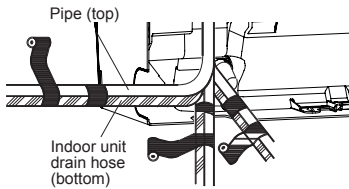
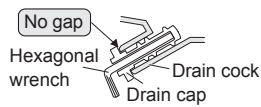

## Removal method of drain hose

- Remove the screw at the left of drain hose and pull out drain hose.

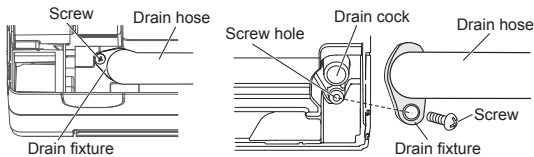

- Please hold around the joint of the drain hose during working.
- As the screw is inside, be sure to use screwdriver treated with magnet.
- For left piping and left rear piping, align the marks on the wall hook bracket and shape the connection pipe.
- Bend the connection piping at a bend radius of 70 mm (2-3/4 in.) or more and install no more than 35 mm (1-3/8 in.) from the wall.
- After passing the indoor piping and drain hose through the wall hole, hang the indoor unit on the hooks at the top and bottom of the wall hook bracket.

## Installation method of drain hose

- Vertically insert the drain hose toward the inside, so that the drain fixture (white) can accurately align with the screw hole around the drain cock. After inserting and before replacing, please reinstall and fix the removed screws.

## [Installing the indoor unit]

- Hang the indoor unit from the hooks at the top of the wall hook bracket.
- Insert the spacer, etc. between the indoor unit and the wall hook bracket and separate the bottom of the indoor unit from the wall.

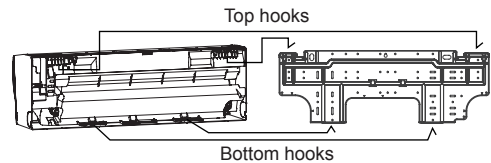
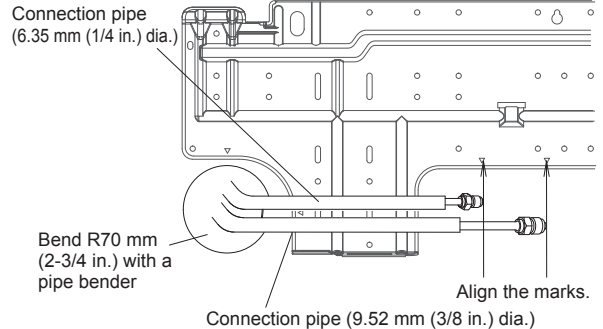
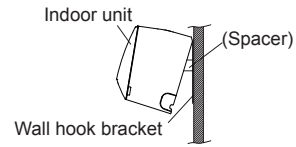

After hooking the indoor unit to the top hook, hook the fittings of the indoor unit to the 2 bottom hooks while lowering the unit and pushing it against the wall.

## 6.6. Flare connection (Pipe connection)

### CAUTION

- Tighten the flare nuts with a torque wrench using the specified tightening method. Otherwise, the flare nuts could break after a prolonged period, causing refrigerant to leak and generate hazardous gas if the refrigerant comes into contact with a flame.

### 6.6.1. Flaring

- Use special pipe cutter and flare tool exclusive for R410A.
  - Cut the connection pipe to the necessary length with a pipe cutter.
  - Hold the pipe downward so that cuttings will not enter the pipe and remove any burrs.
  - Insert the flare nut (always use the flare nut attached to the indoor unit(s) and outdoor unit or branch box respectively) onto the pipe and perform the flare processing with a flare tool. Use the special R410A flare tool, or the conventional flare tool. Leakage of refrigerant may result if other flare nuts are used.
  - Protect the pipes by pinching them or with tape to prevent dust, dirt, or water from entering the pipes.

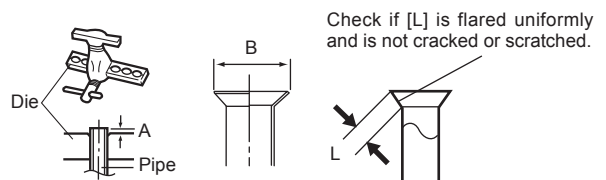

Pipe outside diameter [mm (in.)]	Dimension A [mm (in.)]	Dimension B [mm (in.)]
	Flare tool for R410A, clutch type	
6.35 (1/4)	0 to 0.5 (0 to 0.020)	9.1 (11/32)
9.52 (3/8)		13.2 (17/32)

When using conventional flare tools to flare R410A pipes, the dimension A should be approximately 0.5 mm (0.020 in.) more than indicated in the table (for flaring with R410A flare tools) to achieve the specified flaring. Use a thickness gauge to measure the dimension A.

Pipe outside diameter [mm (in.)]	Width across flats	
	Pipe outside diameter [mm (in.)]	Width across flats of Flare nut [mm (in.)]
6.35 (1/4)	17 (21/32)	
9.52 (3/8)	22 (7/8)	



### 6.6.2. Bending pipes

- If pipes are shaped by hand, be careful not to collapse them.
- Do not bend the pipes in an angle more than 90°.
- When pipes are repeatedly bent or stretched, the material will harden, making it difficult to bend or stretch them any more.
- Do not bend or stretch the pipes more than 3 times.

#### CAUTION

- To prevent breaking of the pipe, avoid sharp bends.
- If the pipe is bent repeatedly at the same place, it will break.

### 6.6.3. Pipe connection

#### CAUTION

- Be sure to install the pipe against the port on the indoor unit correctly. If the centering is improper, the flare nut cannot tighten smoothly. If the flare nut is forced to turn, the threads will be damaged.
- Do not remove the flare nut from the indoor unit pipe until immediately before connecting the connection pipe.
- Hold the torque wrench at its grip, keeping it at a right angle with the pipe, in order to tighten the flare nut correctly.
- Tighten the flare nuts with a torque wrench using the specified tightening method. Otherwise, the flare nuts could break after a prolonged period, causing refrigerant to leak and generate hazardous gas if the refrigerant comes into contact with a flame.

#### CAUTION

- Connect the piping so that the control box cover can easily be removed for servicing when necessary.
- In order to prevent water from leaking into the control box, make sure that the piping is well insulated.

When the flare nut is tightened properly by your hand, hold the body side coupling with a wrench, then tighten with a torque wrench. (See the table below for the flare nut tightening torques.)

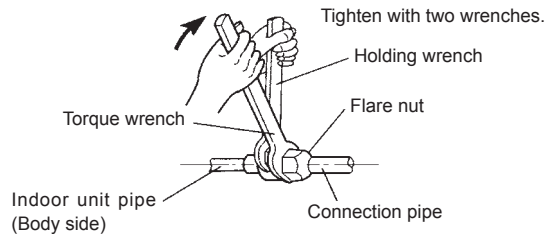

Flare nut [mm (in.)]	Tightening torque [N·m (lb·ft)]
6.35 (1/4) dia.	16 to 18 (11.8 to 13.3)
9.52 (3/8) dia.	32 to 42 (23.6 to 31.0)

## 7. ELECTRICAL WIRING

### 7.1. Wiring system diagram

#### WARNING

- Every wire must be connected firmly.
- No wire should be allowed to touch refrigerant tubing, the compressor or any moving part.
- Loose wiring may cause the terminal to overheat or result in unit malfunction. A fire hazard may also exist. Therefore, be sure all wiring is tightly connected.
- Connect wires to the matching numbers of terminals.

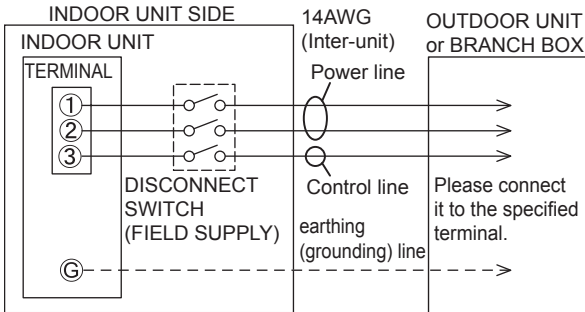

Disconnect switch - field supplied if required by local code. Select the correct capacity of disconnect switch according to the load.

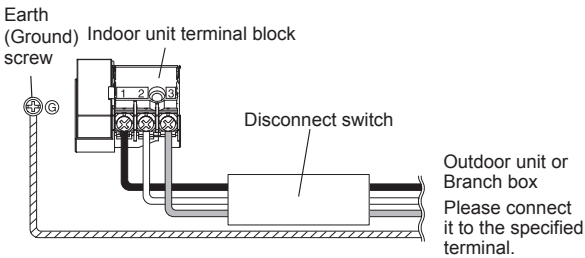

- To connect the indoor unit wires to the terminal correctly, refer to the figure for proper length.

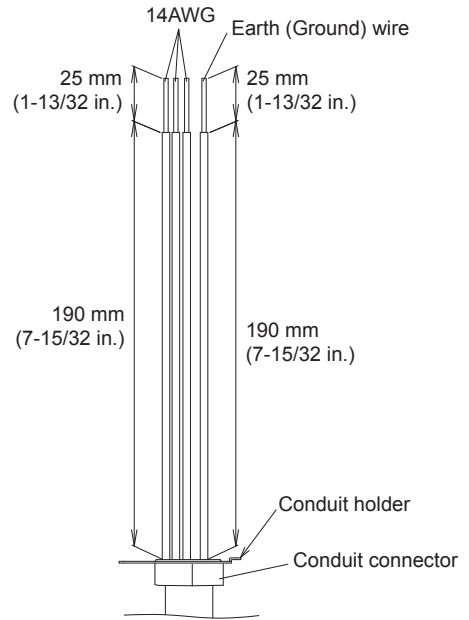

### 7.2. How to the install the indoor unit wire harness

1. Remove the screws, then remove the conduit holder.
2. Fasten the indoor unit wire harness to the conduit holder using the lock nut.  
**IMPORTANT:** Refer to [7.1. Wiring system diagram] about the length of indoor unit wire harness.
3. Use the screws to install the conduit holder provide with the indoor unit.
4. Remove the screws, then remove the cable clammer.
5. Connect indoor unit wire harness to the terminal.  
Refer to the wiring diagram.
6. Use the screws to install the cable clammer.

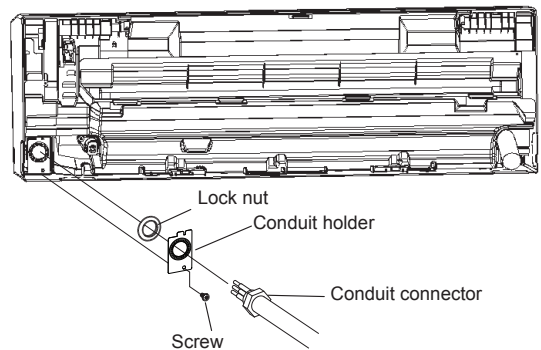

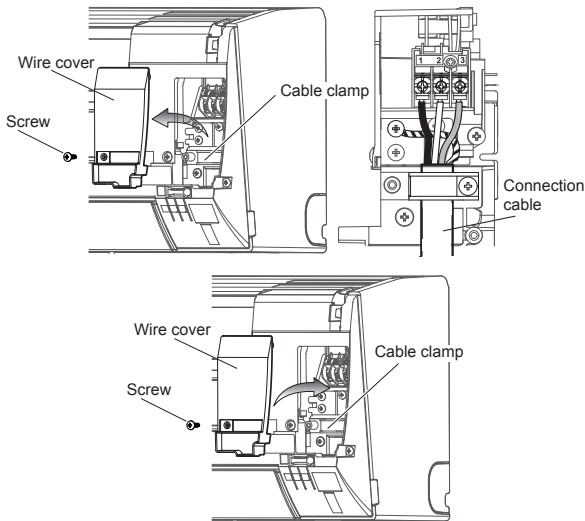

Insert the wire cover tab into the square hole of the indoor unit and fasten with a screw.

### 7.3. How to connect wiring to the terminals

#### Caution when wiring cable

- When stripping off the insulation of a lead wire, always use a special tool such as a wire stripper. If there is no special tool available, carefully strip the insulation with a knife etc.
- Use crimp-type terminals with insulating sleeves as shown in the figure below to connect to the terminal block.
  - Securely clamp the crimp-type terminals to the wires using an appropriate tool so that the wires do not come loose.

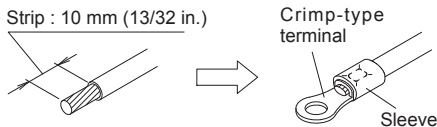

- Use the specified wires, connect them securely, and fasten them so that there is no stress placed on the terminals.
- Use an appropriate screwdriver to tighten the terminal screws. Do not use a screwdriver that is too small, otherwise, the screw heads may be damaged and prevent the screws from being properly tightened.
- Do not tighten the terminal screws too much, otherwise, the screws may break.

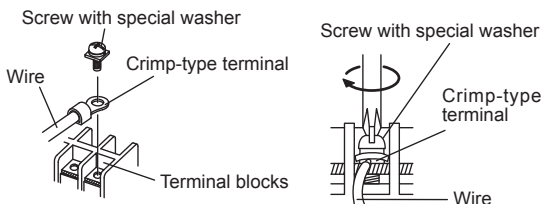

- See the table below for the terminal screw tightening torques.

Tightening torque [N·m (lbf·in)]	
M4 screw	1.2 to 1.8 (11 to 16)

#### **CAUTION**

- Match the terminal block numbers and connection cable colors with those of the outdoor unit or branch box. Erroneous wiring may cause burning of the electric parts.
- Connect the connection cables firmly to the terminal block. Imperfect installation may cause a fire.
- Always fasten the outside covering of the connection cable with the cable clamp. (If the insulator is chafed, electric discharge may occur.)
- Always connect the earth (ground) wire.
- Do not use the earth (ground) screw of the indoor unit for the connection other than a specified outdoor unit or branch box.

## 8. FINISHING

- (1) Insulate between pipes.
  - For rear, right, and bottom piping, overlap the connection pipe insulation and indoor unit pipe insulation and bind them with vinyl tape so that there is no gap.
  - For left and left rear piping, butt the connection pipe insulation and indoor unit pipe insulation together and bind them with vinyl tape so that there is no gap.
  - For left and left rear piping, wrap the area which accommodates the rear piping storage section with cloth tape.
  - For left and left rear piping, bind the connection cord to the top of the pipe with vinyl tape.
  - For left and left rear piping, bundle the piping and drain hose together by wrapping them with cloth tape over within the range of which they fit into the rear piping storage section.
- (2) Temporarily fasten the connection cord along the connection pipe with vinyl tape. (Wrap to about 1/3 the width of the tape from the bottom of the pipe with tape so that water does not enter.)
- (3) Fasten the connection pipe to the outside wall with saddles, etc.
- (4) Fill the gap between the outside wall pipe hole and the pipe with sealant so that rain water and wind cannot blow in.
- (5) Fasten the drain hose to the outside wall, etc.

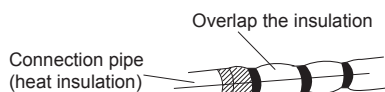
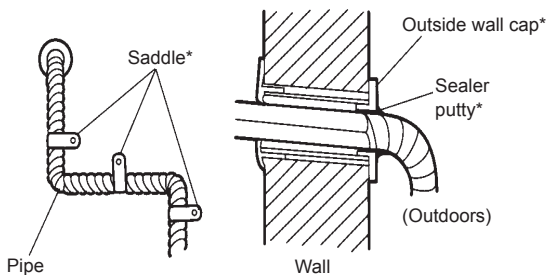

Bind the pipes together so that there is no gap.

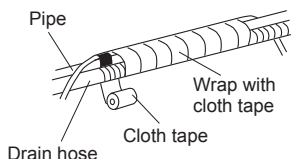

### Left piping

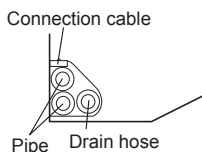

### For connection from the left rear

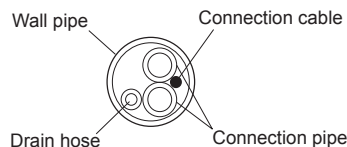

### Check the following:

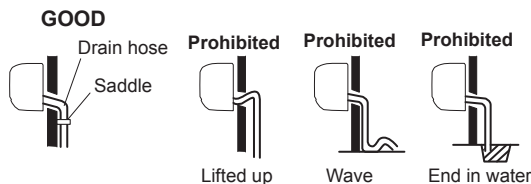

## 9. FRONT PANEL REMOVAL AND INSTALLATION

### Intake grill removal

Open the intake grille. While gently pressing the left and right mounting shafts of the intake grille outward "a", remove the intake grille in direction of the arrow "b".

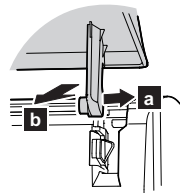

### Intake grill installation

While holding the grille horizontal, set the left and right mounting shafts into the pillow blocks at the top of the panel "c". To latch each shaft properly, insert the shaft until it snaps.

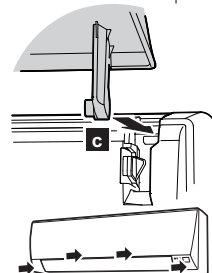

Press 4 places on the intake grille to close it completely.

### Front panel removal

- (1) Remove intake grille (Reference the intake grille removal.)
- (2) Remove wire cover.
- (3) Remove 3 screws.

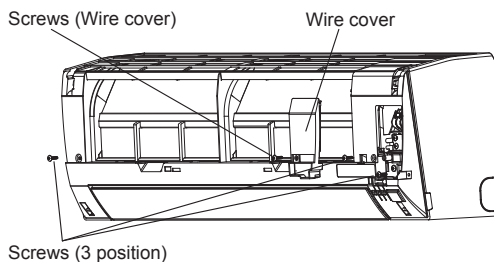

- (4) The front panel is pulled to the front, raising the upper surface, and a front panel is removed.

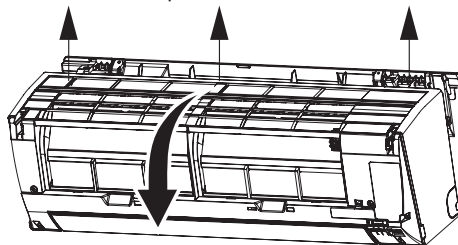

## Front panel installation

- Firstly, fit the lower part of the front panel, and insert top and bottom hooks. ( 3 top sides, 6 bottom sides)

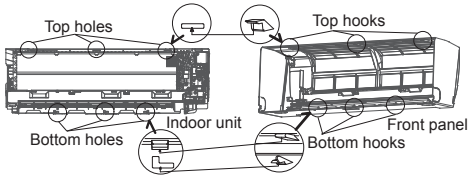

- Three screws is attached.
- The wire cover is attached.
- The intake grille is attached.

### ⚠ CAUTION

- Install the Front panel and Intake grille securely. If installation is imperfect, the Front panel or Intake grille may fall off and cause injury.

## 10. TEST RUN

### Check items

- Is operation of each button on the remote controller unit normal?
  - Does each lamp light normally?
  - Do airflow direction louvers operate normally?
  - Is the drain normal?
  - Do not have an abnormal noise and vibration during operation?
- Do not operate the air conditioner in test run for a long time.

### [Operation method]

- For the operation method, refer to the operating manual.
- The outdoor unit, may not operate, depending on the room temperature. In this case, keep on pressing the MANUAL AUTO button of the indoor unit for more than 10 seconds. The OPERATION indicator lamp (green) and TIMER indicator lamp (orange) will begin to flash simultaneously during cooling test run. Then, heating test run will begin in about 3 minutes when HEAT is selected by the remote control operation. (Please follow the operating manual for remote control operation.)  
(When the air conditioner is running by pressing the test run button, the OPERATION indicator lamp and TIMER indicator lamp will simultaneously flash slowly.)

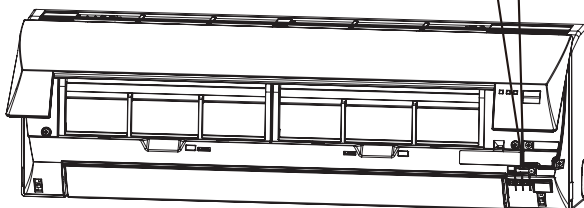
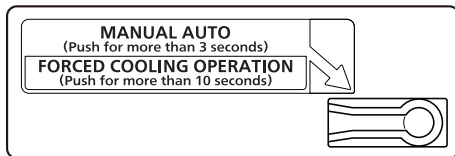

- When ending the test run, keep on pressing the MANUAL AUTO button of the indoor unit for more than 3 seconds.

## 11. REMOTE CONTROLLER INSTALLATION

### ⚠ CAUTION

- Check that the indoor unit correctly receives the signal from the remote controller, then install the remote controller holder.
- Select the remote controller holder selection site by paying careful attention to the following:  
Avoid places in direct sunlight.  
Select a place that will not be affected by the heat from a stove, etc.

### 11.1. Remote controller holder installation

- Install the remote controller a maximum distance of 7 m (23 ft) from the remote control receiver. However, when installing the remote controller, check that it operates correctly.
- Install the remote controller holder to a wall, pillar, etc. with the tapping screw.

#### remote controller holder fixing

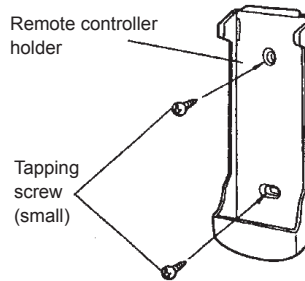

#### remote controller mounting

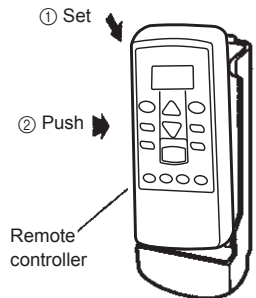

## 12. FUNCTION SETTING

### 12.1. INDOOR UNIT (Setting by remote controller)

- The function settings of the control of the indoor unit can be changed by this procedure according to the installation conditions. Incorrect settings can cause the indoor unit malfunction.
- After the power is turned on, perform the "FUNCTION SETTING" according to the installation conditions using the remote controller.
- The settings may be selected between the following two: Function Number or Setting Value.
- Settings will not be changed if invalid numbers or setting values are selected.

### ■ PREPARATION

- Turn on the power
- \* By turning on the power indoor units, so make sure the piping air-tight test and vacuuming have been conducted before turning on the power.
- \* Also check again to make sure no wiring mistakes were made before turning on the power.

### ■ FUNCTION SETTING METHOD (for Wireless remote controller)

#### Entering the Function Setting Mode

- While pressing the FAN button and SET TEMP. (▲) button simultaneously, press the RESET button to enter the function setting mode.

#### STEP 1

#### Setting the Remote controller Signal Code

Use the following steps to select the signal code of the remote controller. (Note that the air conditioner cannot receive a signal code if the air conditioner has not been set for the signal code.)

The signal code that is set through this process are applicable only to the signal in the FUNCTION SETTING.

For details on how to set the signal code through the normal process, refer to SELECTING THE REMOTE CONTROLLER SIGNAL CODE.

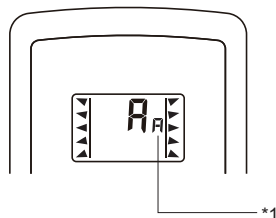

- 1 Press the SET TEMP. (▲)(▼) button to change the signal code between  $\overline{A} \rightarrow \overline{b} \rightarrow \overline{c} \rightarrow \overline{d}$ . Match the code on the display to the air conditioner signal code. (initially set to  $\overline{A}$ ) (If the signal code does not need to be selected, press the MODE button and proceed to STEP 2.)
- 2 Press the MODE button to accept the signal code, and proceed to STEP 2

The air conditioner signal code is set to  $\overline{A}$  prior to shipment. Contact your retailer to change the signal code.

The remote controller resets to signal code  $\overline{A}$  when the batteries in the remote controller are replaced. If you use a signal code other than signal code  $\overline{A}$ , reset the signal code after replacing the batteries. If you do not know the air conditioner signal code setting, try each of the signal codes ( $\overline{A} \rightarrow \overline{b} \rightarrow \overline{c} \rightarrow \overline{d}$ ) until you find the code which operates the air conditioner.

#### STEP 2

#### Setting the Remote controller Signal Code

- 1 Press the SET TEMP. (▲) (▼) buttons to select the function number. (Press the MODE button to switch between the left and right digits.)

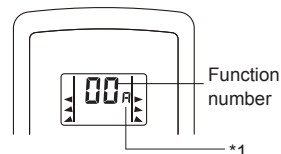

- 2 Press the FAN button to proceed to setting the value. (Press the FAN button again to return to the function number selection.)

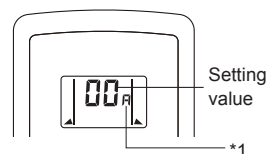

- 3 Press the SET TEMP. (▲) (▼) buttons to select the setting value. (Press the MODE button to switch between the left and right digits.)
- 4 Press the SLEEP button, then after you hear the beep emitted from the indoor unit, press the START/STOP button to confirm the settings.
- 5 Press the RESET button to cancel the function setting mode.
- 6 After completing the FUNCTION SETTING, be sure to turn off the power and turn it on again.

#### ⚠ CAUTION

After turning off the power, wait 10 seconds or more before turning on it again.

The FUNCTION SETTING doesn't become effective if it doesn't do so.

Note :

- \*1) Small "A" is displayed on the right of the signal code during the FUNCTION SETTING.

### ■ FUNCTION DETAILS

	Functions	Compact wall mounted
1)	Filter sign	●
2)	Cooler room temperature correction	●
3)	Heater room temperature correction	●
4)	Auto restart	●
5)	Remote controller signal code	●

### 1) Filter sign

The indoor unit has a sign to inform the user that it is time to clean the filter. Select the time setting for the filter sign display interval in the table below according to the amount of dust or debris in the room. If you do not wish the filter sign to be displayed, select the setting value for "No indication".

(◆... Factory setting)

Setting Description	Function Number	Setting Value
Standard	11	00
Long interval		01
Short interval		02
No indication		03

The filter sign interval time is different according to Indoor unit type as follows.

Setting description	Compact Wall Mounted
Standard	400 hours
Long interval	1000 hours
Short interval	200 hours

### 2) Cooler room temperature correction

Depending on the installed environment, the room temperature sensor may require a correction.

The settings may be selected as shown in the table below.

(◆... Factory setting)

Setting description	Function Number	Setting Value
Standard	30	00
Slightly lower control		01
Lower control		02
Warmer control		03

### 3) Heater room temperature correction

Depending on the installed environment, the room temperature sensor may require a correction.

The settings may be changed as shown in the table below.

(◆... Factory setting)

Setting description	Function Number	Setting Value
Standard	31	00
Lower control		01
Slightly warmer control		02
Warmer control		03

### 4) Auto restart

Enable or disable automatic system restart after a power outage.

(◆... Factory setting)

Setting description	Function Number	Setting Value
Yes	40	00
No		01

\* Auto restart is an emergency function such as for power failure etc. Do not start and stop the indoor unit by this function in normal operation. Be sure to operate by the control unit, or external input device.

### 5) Remote controller signal code

Change the indoor unit Signal Code, depending on the remote controllers.

(◆... Factory setting)

Setting Description	Function Number	Setting Value
A	44	00
B		01
C		02
D		03

## ■ REMOTE CONTROLLER SIGNAL CODE SETTING

Use the following steps to select the signal code of the remote controller.

(Note that the air conditioner cannot receive a signal code if the air conditioner has not been set for the signal code.)

- 1 Press the MODE button for at least five seconds to display the current signal code (initially set to **A**).

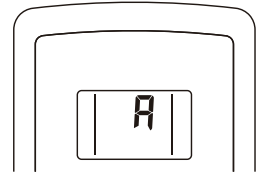

- 2 Press the SET TEMP. (▲) (▼) button to change the signal code between **A** → **B** → **C** → **D**.

Match the code on the display to the air conditioner signal code.

- 3 Press the MODE button again. The signal code will be changed.

If no buttons are pressed within 30 seconds after the signal code is displayed, the display returns to the original status. In this case, start again from step 1.

The air conditioner signal code is set to A prior to shipment.  
Contact your retailer to change the signal code.

The remote controller resets to signal code A when the batteries in the remote controller are replaced. If you use a signal code other than signal code A, reset the signal code after replacing the batteries. If you do not know the air conditioner signal code setting, try each of the signal codes (**A** → **B** → **C** → **D**) until you find the code which operates the air conditioner.

## 13. ERROR CODES

If you use a wireless remote controller, the lamp on the photo detector unit will output error codes by way of blinking patterns. See the lamp blinking patterns in the table. An error display is displayed only during operation.

### [ Troubleshooting with the indoor unit display ]

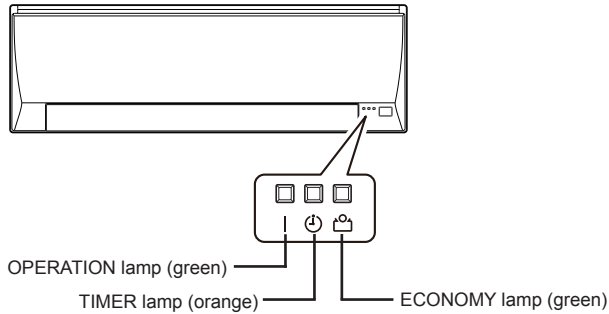

Error display			Description
OPERATION lamp (green)	TIMER lamp (orange)	ECONOMY lamp (green)	
● (1)	● (1)	◇	Serial communication error
● (3)	● (2)	◇	Indoor unit PCB model information error
● (3)	● (5)	◇	Manual auto switch error
● (4)	● (1)	◇	Room temp. sensor error
● (4)	● (2)	◇	Indoor unit Heat Ex. Middle temp.sensor error
● (5)	● (1)	◇	Indoor unit fan motor error
● (5)	● (15)	◇	Indoor unit error
● (6)	● (2)	◇	Outdoor unit main PCB model information error or communication error
● (6)	● (3)	◇	Inverter error
● (6)	● (4)	◇	Active filter error, PFC circuit error
● (6)	● (5)	◇	Trip terminal L error
● (6)	● (10)	◇	Display PCB microcomputers communication error
● (7)	● (1)	◇	Discharge temp. sensor error
● (7)	● (3)	◇	Outdoor unit Heat Ex. liquid temp. sensor error
● (7)	● (4)	◇	Outdoor temp. sensor error
● (8)	● (4)	◇	Current sensor error
● (9)	● (4)	◇	Trip detection
● (9)	● (5)	◇	Compressor rotor position detection error
● (9)	● (7)	◇	Outdoor unit fan motor error
● (9)	● (9)	◇	4-way valve error
● (10)	● (1)	◇	Discharge temp. error

Display mode ● : 0.5s ON / 0.5s OFF  
 ◇ : 0.1s ON / 0.1s OFF  
 ( ) : Number of flashing

## 14. CUSTOMER GUIDANCE

Explain the following to the customer in accordance with the operating manual:

- (1) Starting and stopping method, operation switching, temperature adjustment, timer, air flow switching, and other remote control unit operations.
- (2) Air filter removal and cleaning, and how to use the air louvers.
- (3) Give the operating manual to the customer.